

## Datasheet

Model: KH-VH-PT3.96

### SPECIFICATION

↵

Poles: 2~16↵

Applicable wires: AWG22 # ~18#↵

Applicable PC board thickness: 1.6mm↵

Temperature range: -25°C~85°C↵

Voltage rating: 250V.AC/DC↵

Current rating: 7.5A↵

Contact resistance:  $\leq 0.015\Omega$ ↵

Insulation resistance:  $\geq 1000\Omega$ ↵

Withstand voltage: 1500V.AC/1min↵

### MATERIAL

Terminal: Phos.bronze Tin/plated

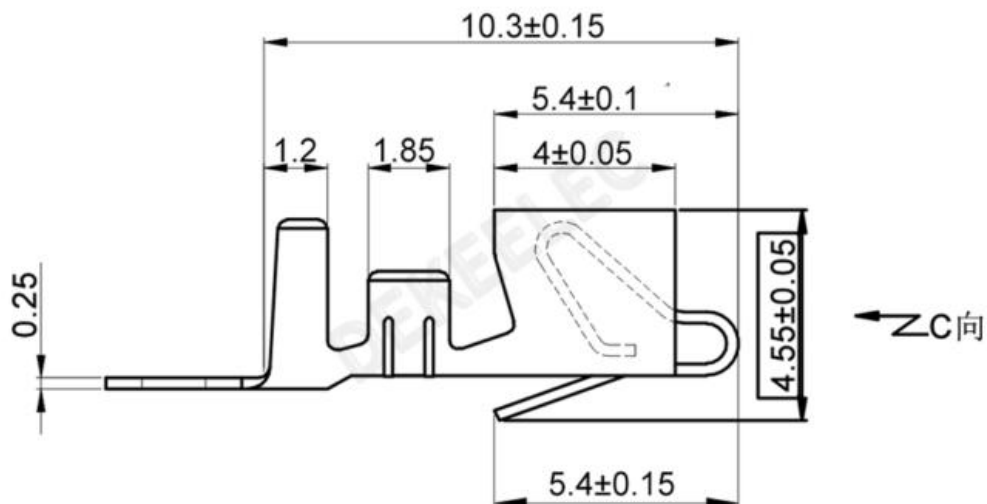

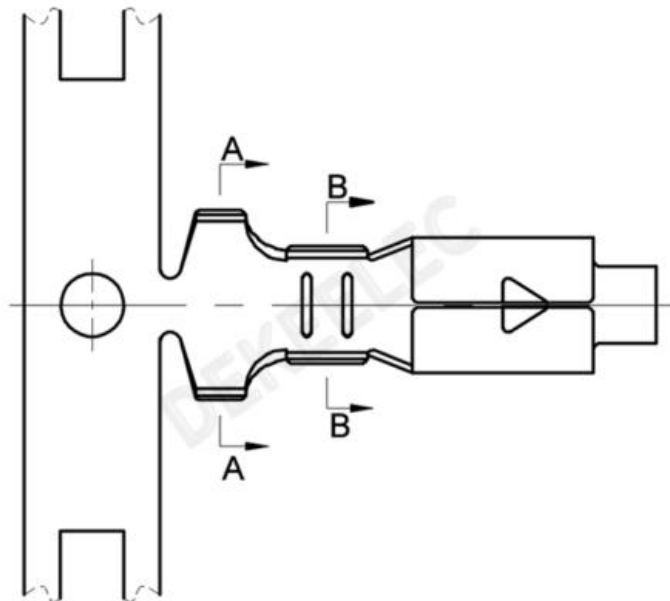
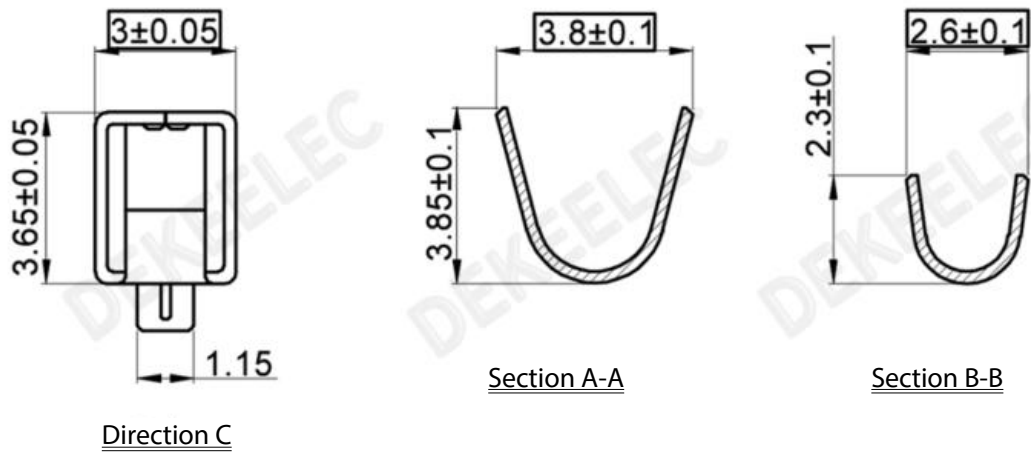

## Terminal (VH)

Type	Applicable wires		O.D of wire ins
	mm <sup>2</sup>	AWG#	mm
VH-PT	0.33~0.83	22-18	1.7-3.0