

Product specifications

Date : 2016.05.28

Product name : Tact Switch

Model : KH-6X6X11H-TJ

Dimension : 6*6* 11

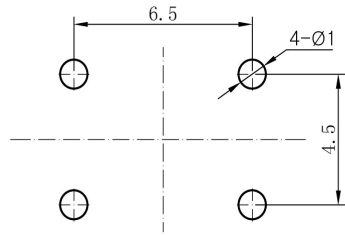
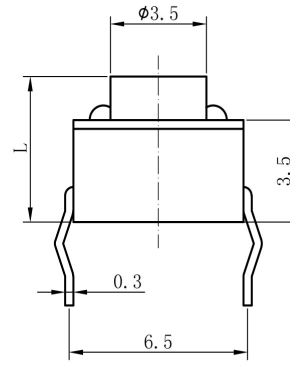
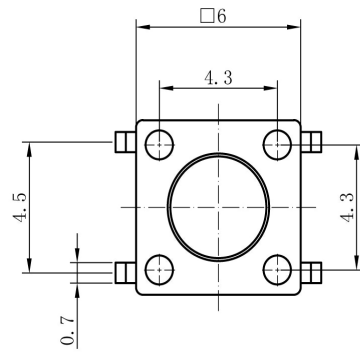
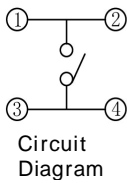
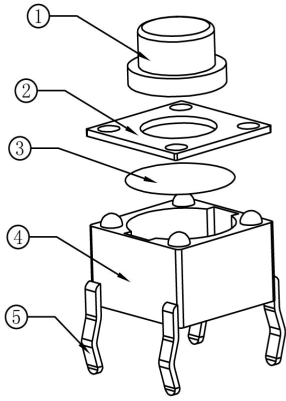

Installation diagram of PCB circuit board(±0.1)

Technical Specifications :

1. Practical temperature: -25~+85
2. Rating: DC 120V 0.1A
3. Contact Resistance: 30m
4. Insulation Resistance: 100m
5. Withstand Voltage: AC250V (50Hz)/min
6. Operating force: 260g±30
7. Service Life: 100000 times
8. Height L and sizes can be optional as required by customers
9. The unspecified dimensional tolerance shall be in accordance with the table in the lower left corner

29	SH-TS-0128-00-29	26.0
28	SH-TS-0128-00-28	24.0
27	SH-TS-0128-00-27	22.0
26	SH-TS-0128-00-26	21.0
25	SH-TS-0128-00-25	20.0
24	SH-TS-0128-00-24	19.0
23	SH-TS-0128-00-23	18.0
22	SH-TS-0128-00-22	17.0
21	SH-TS-0128-00-21	16.0
20	SH-TS-0128-00-20	15.0
19	SH-TS-0128-00-19	14.0
18	SH-TS-0128-00-18	13.0
17	SH-TS-0128-00-17	12.5
16	SH-TS-0128-00-16	12.0
15	SH-TS-0128-00-15	11.0
14	SH-TS-0128-00-14	10.5
13	SH-TS-0128-00-13	10.0
12	SH-TS-0128-00-12	9.5
11	SH-TS-0128-00-11	9.0
10	SH-TS-0128-00-10	8.5
9	SH-TS-0128-00-09	8.0
8	SH-TS-0128-00-08	7.5
7	SH-TS-0128-00-07	7.0
6	SH-TS-0128-00-06	6.5
5	SH-TS-0128-00-05	6.0
4	SH-TS-0128-00-04	5.5
3	SH-TS-0128-00-03	5.0
2	SH-TS-0128-00-02	4.5
1	SH-TS-0128-00-01	4.3

N	Part NO.	Height
O		L(mm)

Unspecified tolerance (±)

Grade	A	B	C
0~4	0.03	0.10	0.20
4~16	0.08	0.15	0.30
16~64	0.12	0.25	0.50
64~250	0.25	0.40	0.80

No.	Quantity	Materials	Remark	Approval
1	1	HR2V T=0.3	Cu/ep.Cu.Sm2	Revised Document Number/ Quantity/ Document No./ Signature/ Date
5	1	PA66 BLACK		Designed
4	1	Silver Steel Belt T=0.1		Checked
3	1	Cold rolled steel strip T=0.3	Cu/ep.Cu.Sm2	Craft
2	1	PA66 BLACK		Standardization

SHENZHEN KINGHELM ELECTRONIC CO., LTD.	
WWW.BDS666.COM	
KH6X6X11H-TJ	
0755-83044319	

SH-TS-0128-00-00		
Stage Mark	Weight(g)	Scale
		5:1
Page1	1 page in total	

MODEL NO.

Tact Switch

ORGANIZER

HE JUNJU

AUDITING

LAI JIREN

AUTHORIZE

ZHANG SONGQIANG

1. RATING

:DC 12V 50mA

2. ELECTRICAL CHARACTERISTICS

	ITEM	TEST CONDITIONS	PERFORMANCE
2.1	CONTACT RESISTANCE	MEASURED AT SMALL CURRENT (100 mA OR LESS)	30m Ω MAX
2.2	INSULATION RESISTANCE	APPLY A VOLTAGE OF 100V DC FOR 1 MIN, TO FOLLOWING PORTIONS AFTER WHICH MEASUREMENT SHALL BE MADE. (1) BETWEEN BODY AND CONDUCTOR (2) BETWEEN CONDUCTORS NOT TO BE CONTACT.	100M Ω MIN
2.3	DIELECTRIC STRENGTH	AC 250V (50-60Hz) FOR 1 MIN TRIP CURRENT: 0.5mA (1) BETWEEN TERMINALS. (2) BETWEEN INDIVIDUAL TERMINALS AND FRAME.	WITHOUT DAMAGE TO PARTS ARCING OR BREAKDOWN ETC.

3. MECHANICAL CHARACTERISTICS

	ITEM	TEST CONDITIONS	PERFORMANCE
3.1	OPERATING FORCE		PAY ONE'S RESPECTS TO THIRDLU PAGE
3.2	TERMINAL STRENGTH	A STATIC LOAD OF (150gf) SHALL BE APPLIED TO THE TIP OF THE TERMINAL FOR 1 MIN IN ANY DIRECTION	ELECTRICAL CHARACTERISTICS SHALL BE SATISFIED WITHOUT DAMAGE OR EXCESSIVE LOOSENESS OF ACTUATOR
3.3	PRACTICAL TEMPERATURE RANGE	Operate at - 25 - + 70	

Kinghelm®		DOCUMENT NUMBER	
		DATE	2016/5/28
SPECIFICATION		PAGE	5 pages in total, page 4
ITEM	TEST CONDITIONS		PERFORMANCE
3.4	STANDARD ATMOSPHERIC CONDITIONS	UNLESS OTHERWISE SPECIFIED. THE STANDARD RANGE OF ATMOSPHERIC CONDITIONS FOR MAKING MEASUREMENTS AND TESTS ARE AS FOLLOWS: (1) AMBIENT TEMPERATURE: 5°C TO 35°C (2) RELATIVE HUMIDITY: 45% TO 85% (3) AIR PRESSURE : 80Kpa TO 106Kpa	
4. DURABILITY			
4.1	LIFE TEST	WITHOUT LOAD: AN ACTUATOR SHALL BE SUBJECT TO 100,000 CYCLES AT A SPEED OF 20 CYCLES FOR 1 MIN.	(1) CONTACT RESISTANCE SHALL BE 200mΩ MAX (2) MECHANICAL AND ELECTRICAL CHARACTERISTICS SHALL BE SATISFIED.
4.2	HEAT TEST	THE SWITCH SHALL BE STORED AT A TEMPERATURE OF 85±2°C FOR 96 HOURS . AND THEN IT SHALL BE SUBJECTED TO THE CONTROLLED RECOVERY CONDITIONS FOR 1 HOUR AFTER WHICH MEASUREMENT SHALL BE MADE.	THERE SHALL BE NO DAMAGE ON APPEARANCE. MECHANICAL AND ELECTRICAL CHARACTERISTICS SHALL BE SATISFIED.
4.3	COLD TEST	THE SWITCH SHALL BE STORED AT A TEMPERATURE OF -25±3°C FOR 96 HOURS . AND THEN IT SHALL BE SUBJECTED TO THE CONTROLLED RECOVER CONDITIONS FOR 1 HOURS AFTER WHICH MEASUREMENT SHALL BE MADE.	THERE SHALL BE NO DEFORMATION OR CRACKS IN MOLDED PART.
4.4	HOMIDITY TEST	THE SWITCH SHALL BE STORED AT A TEMPERATURE OF 40±2°C AND A HUMIFITY OF 90% TO 96% FOR 96 HOURS . THEN THE SWITCH SHALL BE MAINTAINED AT STANDARD ATMOSPHERIC CONDITION FOR 1 HR FOR OTHER PROCEDURES BE MADE.	

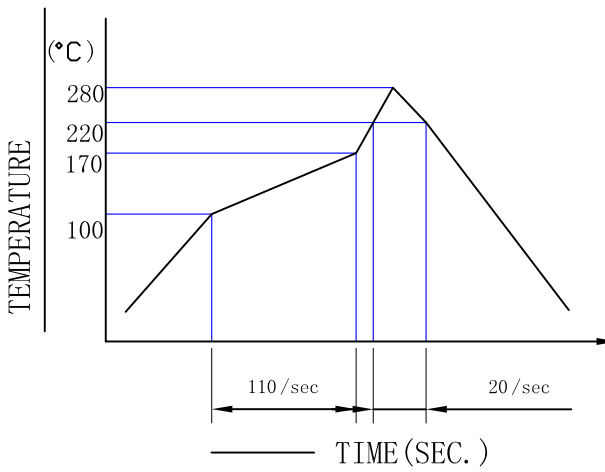
	ITEM	TEST CONDITIONS	PERFORMANCE
4.5	SOLDERING CONDITIONS	<p>HAND SOLDERING: (1) DEVICE: SOLDER IRON A. 350°C MAX . 3SEC MAX B. 270°C MAX . 5SEC MAX (2) REFLOW SOLDERING</p> 	<p>THERE SHALL BE NO DEFORMATION OR CRACKS IN MOLDED PART.</p>

OPERATING FORCE	
260 ± 30gf	