

Rev	ECN Number	Description	Date	Drawn	Checkd	Approved

Technical Requirement

1. Material: Stainless steel SUS304, T=0.08+0.005
2. The soldering and contact surfaces of the terminal must be free from burrs, maximum burr size of 0.03mm allowed on other parts.
3. Torsion: 45° per 1000mm, Arch: 5mm per 1000mm.
4. Dimensions marked with ' ' are critical for control and inspection.
5. Unmarked R MAX R0.13.
6. The plating must pass a 48-hour salt spray test.
7. Life test > 20,000 cycles, product spring force requirement between 60gf to 80gf.
8. Nickel base 50-80µm minimum, gold-plated in the welding area, gold-plated 3µm minimum in the contact area.

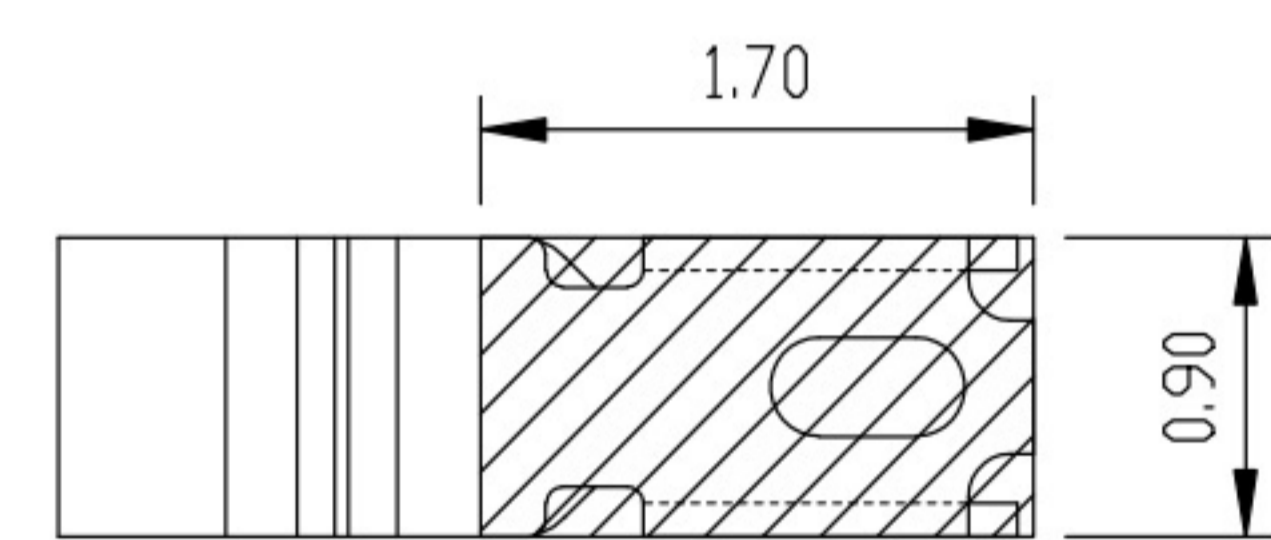
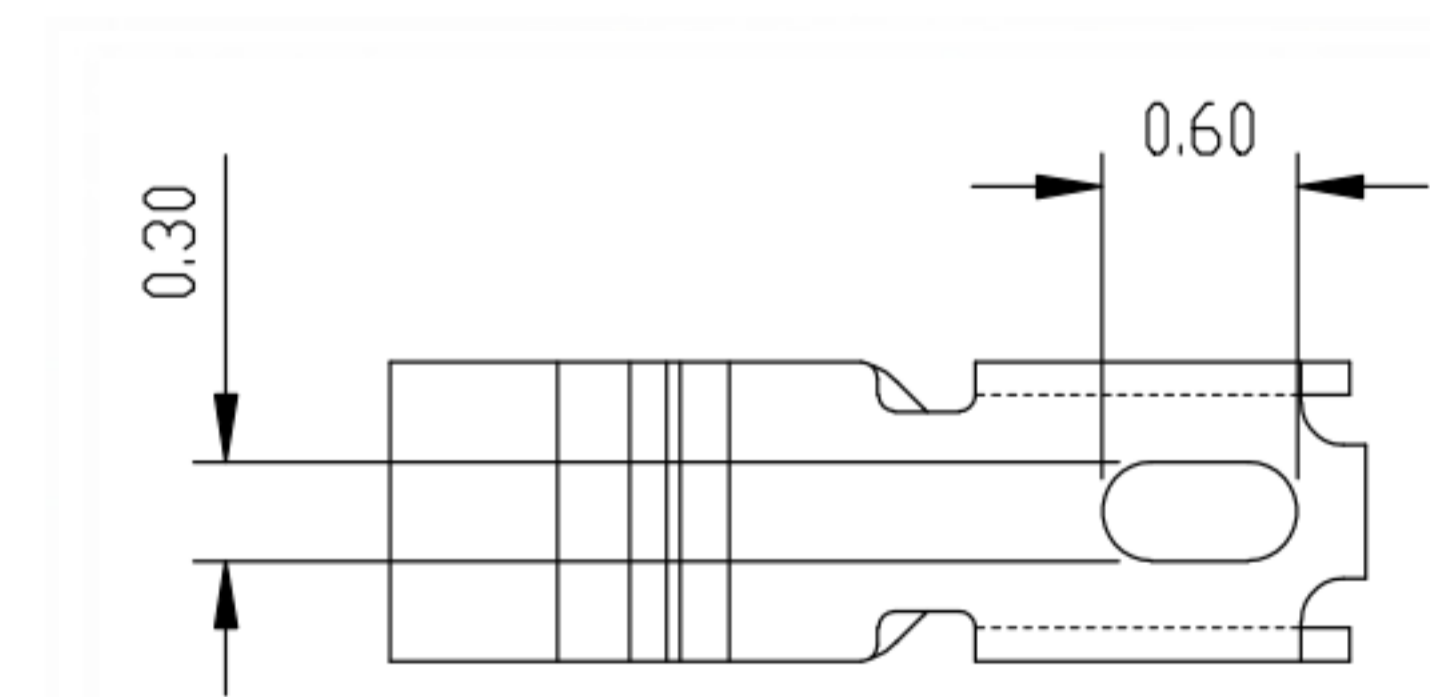
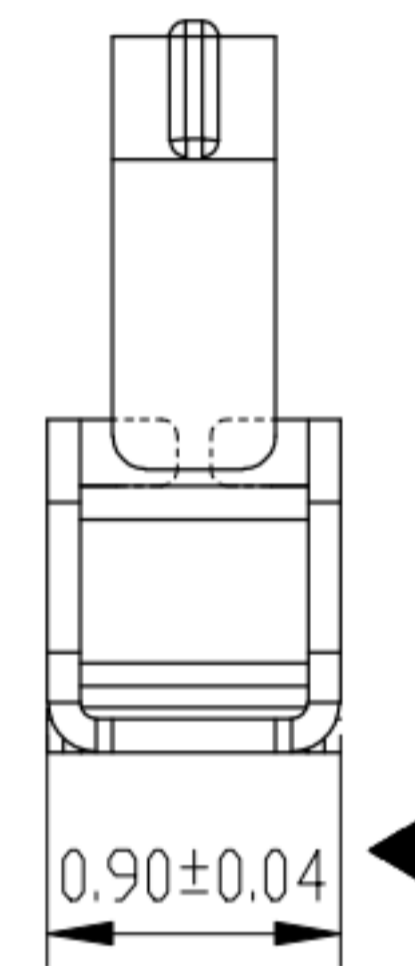
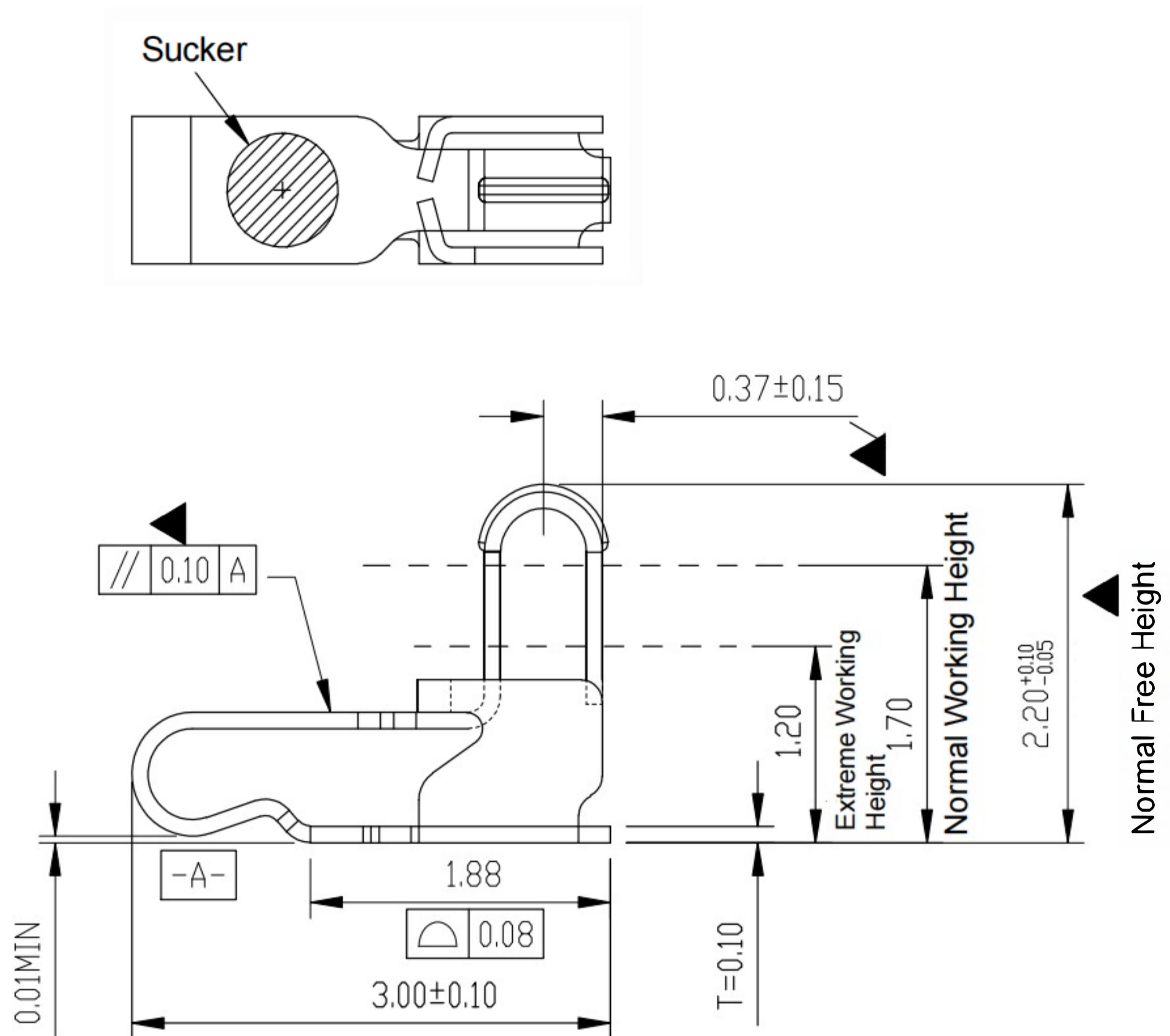

Welding Chassis Dimensions

Dimensional Tolerances ± 0.05

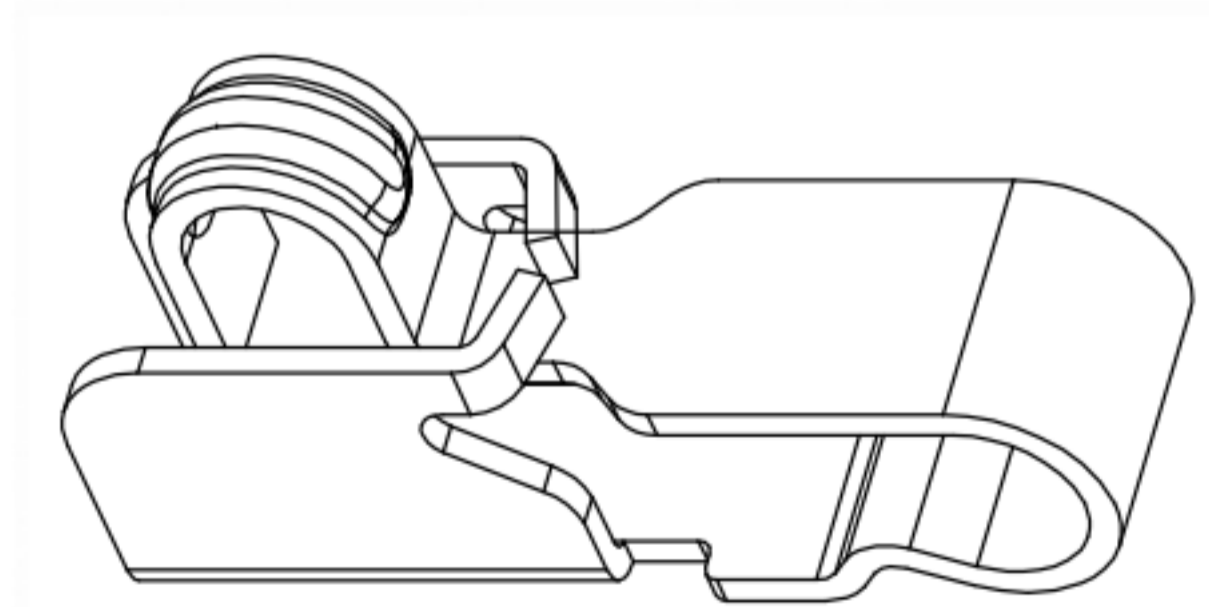

Shenzhen Kinghelm Electronics Co.,Ltd www.kinghelm.net Model: KH-300922-TP 0755-83044319	General Tolerance		Scale: 1:1	Drawn	Date	DWG. No. 681-0033C-1	Diagram for Customer RF Antenna Sprng, SMT, L3.0*W0.9*H2.2mm	REV. A
	X. ± 0.50			Check	Date			Parts No.(Intended Use)
	X. ± 0.35	X.° ± 2.0°	Unit: mm	Approve	Date	JXH0033C2		1/1
	.X ± 0.25	.X° ± 1.0°	Size: A4					
	.XX ± 0.15	.XX° ± 0.5°						