

Rev	ECN Number	Description	Date	Drawn	Checked	Approved

∅0.70 Sucker

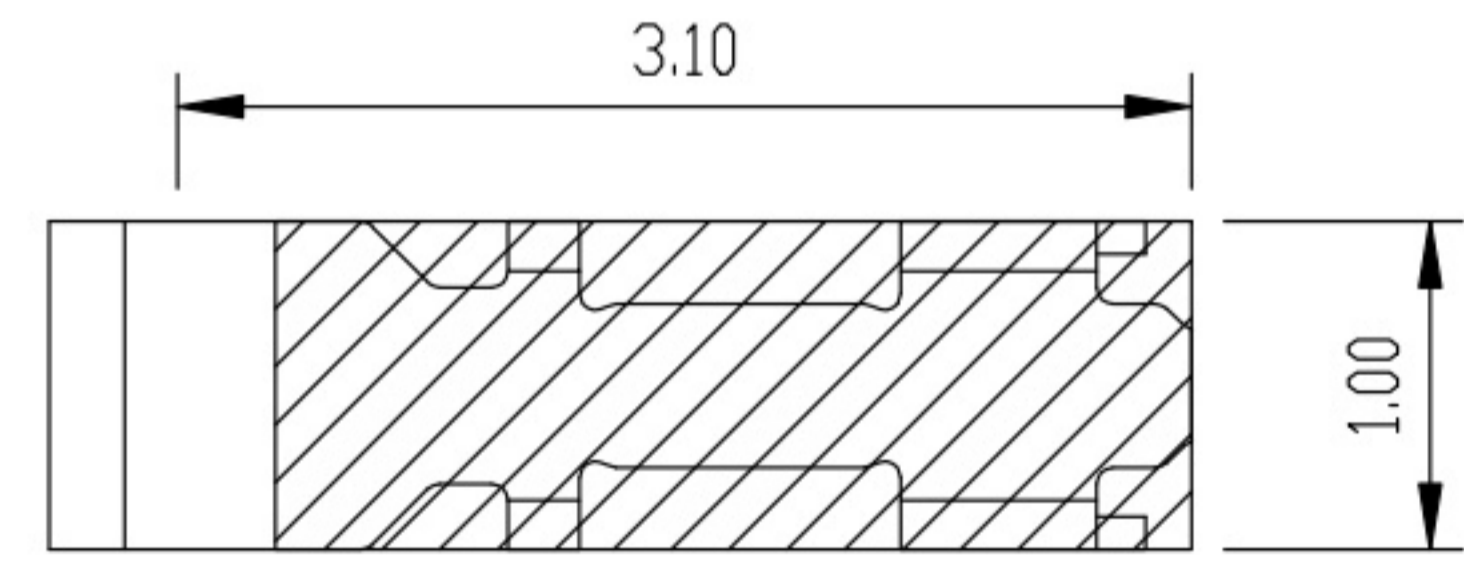

**Welding Chassis Dimensions**  
Dimensional Tolerances  $\pm 0.05$

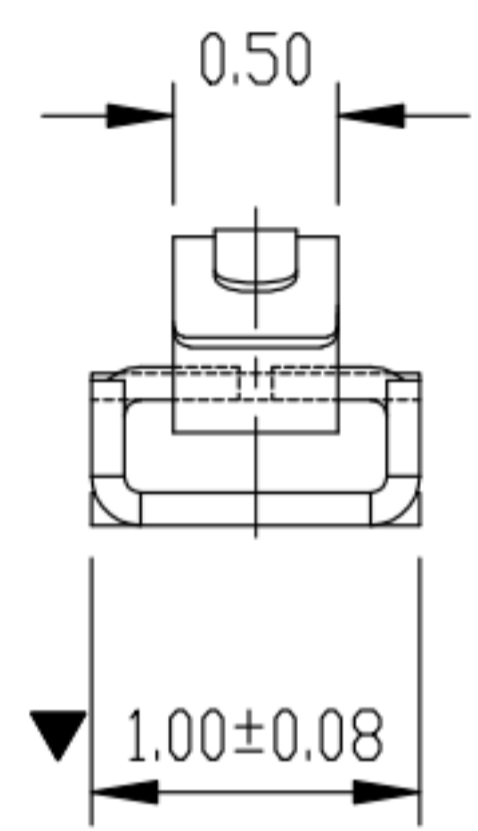
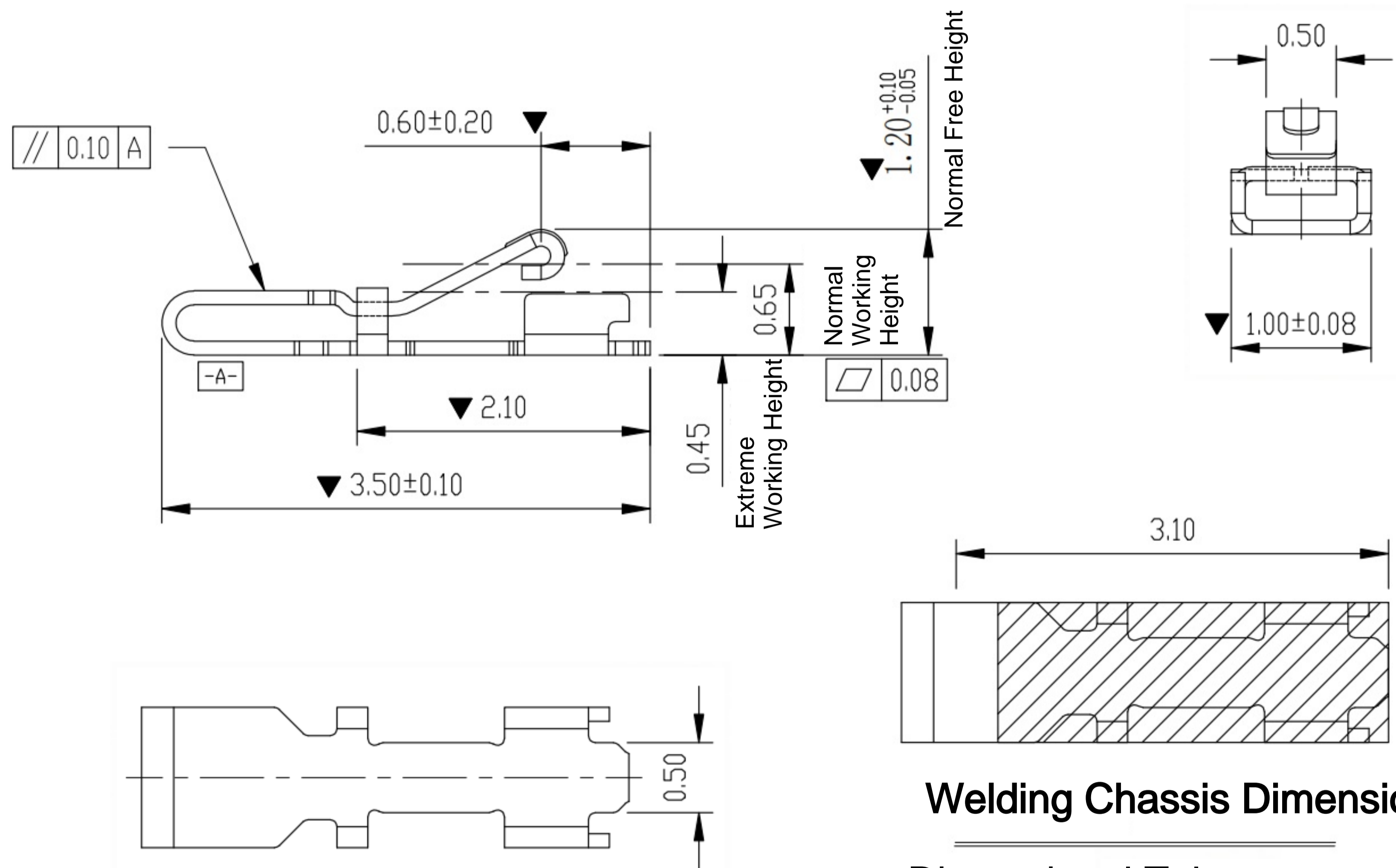
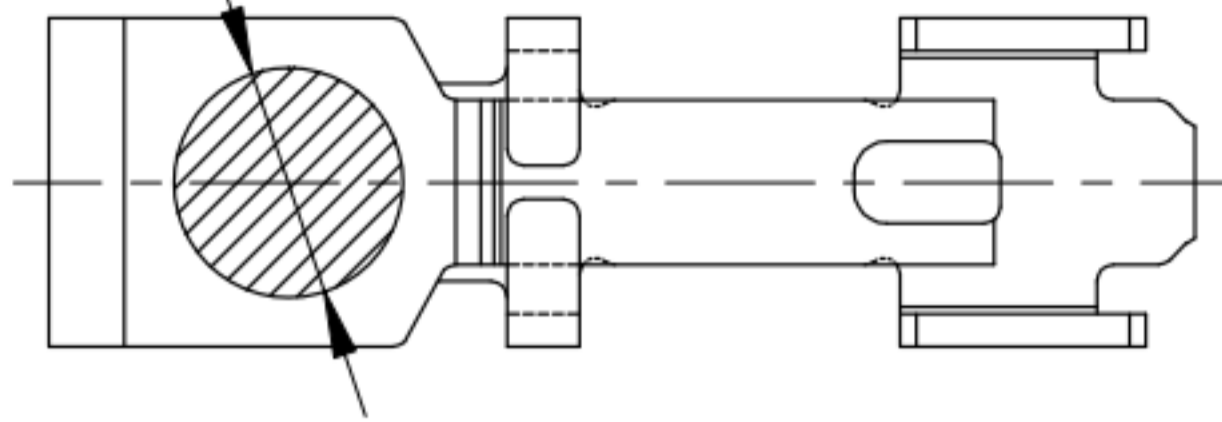
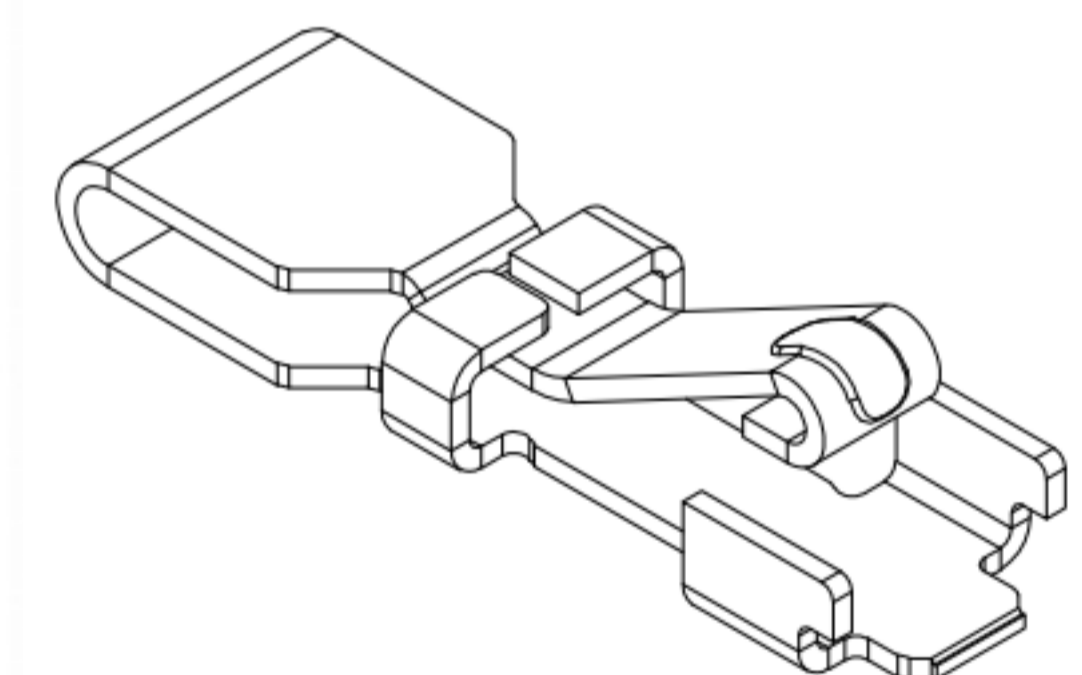

## Technical Requirement

1. Material: Stainless steel SUS304,  $T=0.08 \pm 0.005$ .
2. The soldering and contact surfaces of the terminal must be free from burrs, maximum burr size of 0.03mm allowed on other parts.
3. Torsion:  $45^\circ$  per 1000mm, Arch: 5mm per 1000mm.
4. Dimensions marked with ' ' are critical for control and inspection.
5. Unmarked R MAX R0.13.
6. The plating must pass a 48-hour salt spray test.
7. Life test > 20,000 cycles, product spring force requirement between 60gf to 80gf.
8. Nickel base 50-80 $\mu$ m minimum, gold-plated in the welding area, gold-plated 1 $\mu$ m minimum in the contact area.

Shenzhen Kinghelm Electronics Co.,Ltd www.kinghelm.net Model: KH-351012-TP 0755-83044319	General Tolerance		Scale: 1:1	Drawn	Date	DWG. No. 681-0038A-1	Diagram for Customer RF Antenna Spring, SMT, L3.5*W1.0*H1.2 mm	REV. A
	XX. $\pm 0.50$							Sheet 1/1
	X. $\pm 0.35$	X.° $\pm 2.0^\circ$	Unit: mm	Check	Date	Parts No. (Intended Use) JXH0038A1		
	.X $\pm 0.25$	.X° $\pm 1.0^\circ$	Size: A4	Approved	Date			
	.XX $\pm 0.15$	.XX° $\pm 0.5^\circ$						