

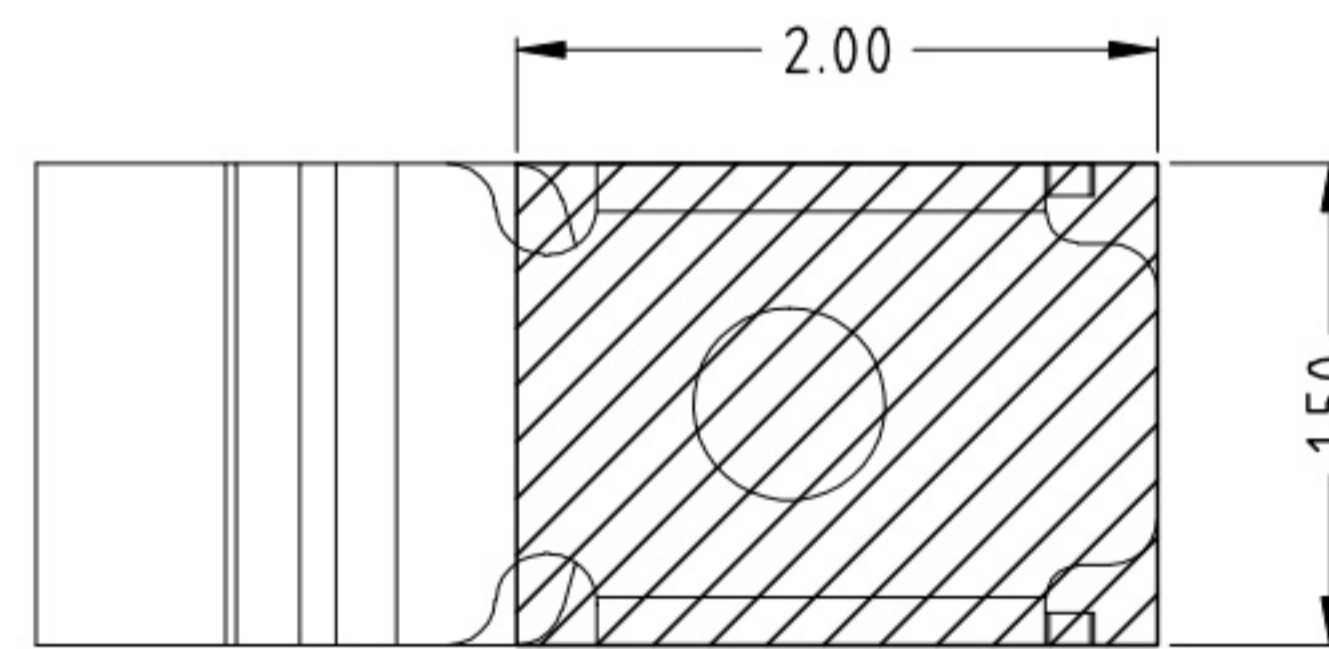

Rev	ECN Number	Description	Date	Drawn	Checked	Approved

Technical Requirement

1. Material: Stainless steel SUS304, T=0.10 ±0.005.
2. The soldering and contact surfaces of the terminal must be free from burrs, maximum burr size of 0.03mm allowed on other parts.
3. Torsion: 45° per 1000mm, Arch: 5mm per 1000mm.
4. Dimensions marked with ' ' are critical for control and inspection.
5. Unmarked R MAX R0.13.
6. The plating must pass a 48-hour salt spray test.
7. Life test > 20,000 cycles, product spring force requirement between 60gf to 80gf.
8. Nickel base 50-80µm minimum, gold-plated in the welding area, gold-plated 1µm minimum in the contact area.

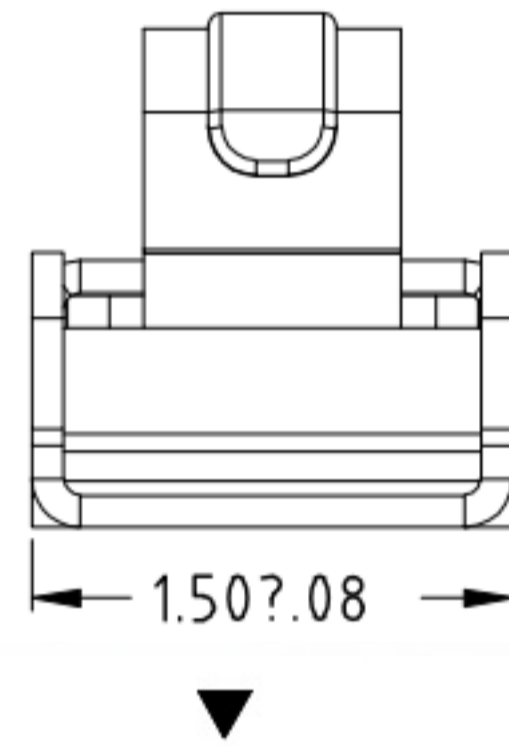
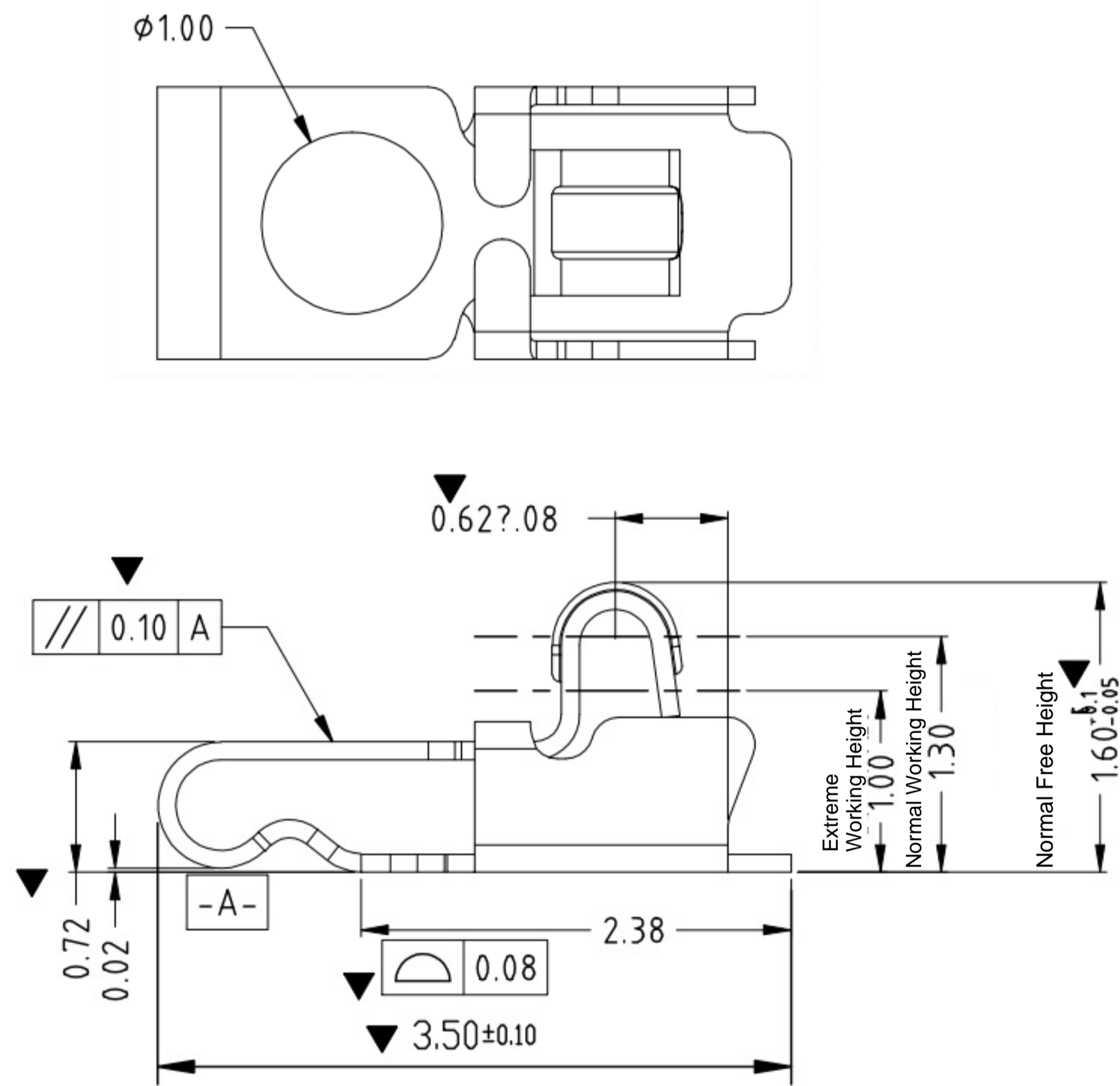

Welding Chassis Dimensions
Dimensional Tolerances ± 0.05

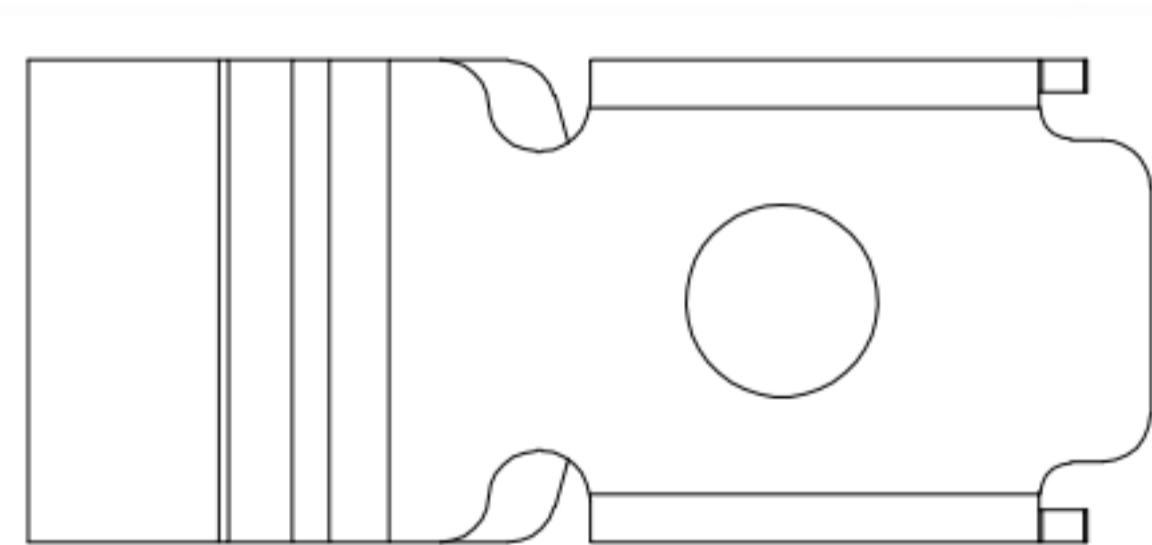
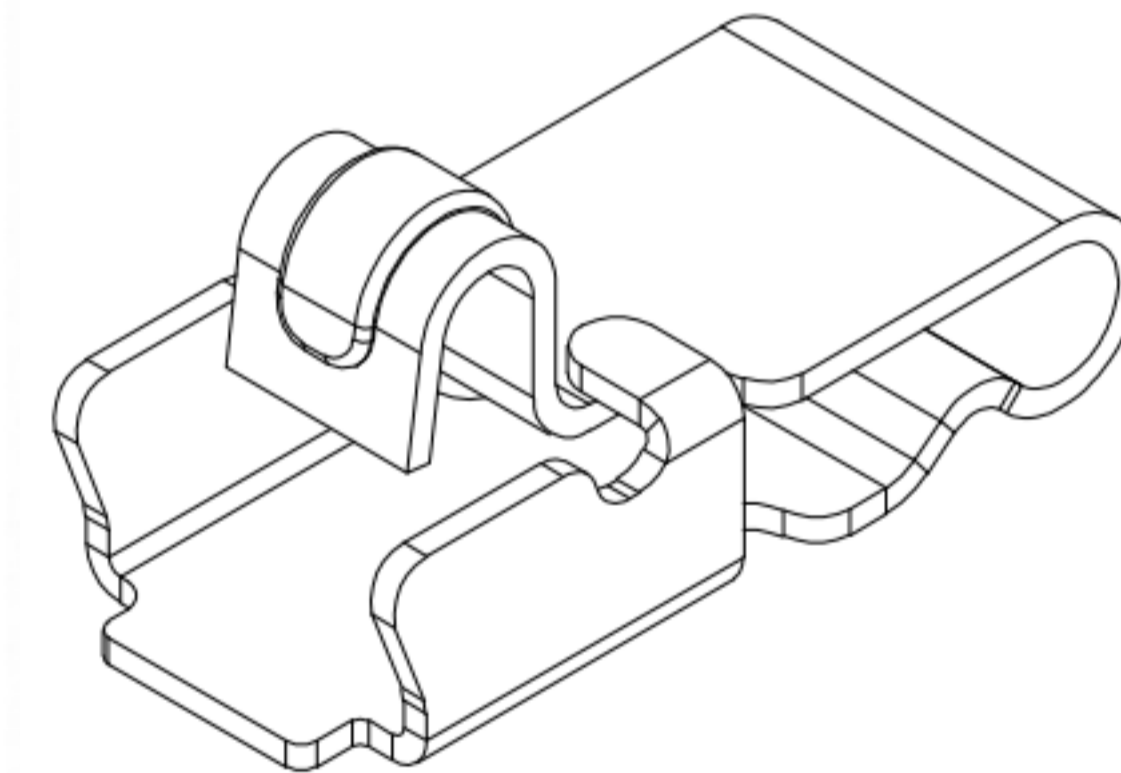

Shenzhen Kinghelm Electronics Co.,Ltd www.kinghelm.net Model: KH-351516-TP 0755-83044319	General Tolerance		Scale: 1:1	Drawn	Date	DWG. No. 681-0029A-1	Diagram for Customer RF Antenna Spring, SMT, L3.5*W1.5*H1.6 mm	REV. A
	XX. ± 0.50	X.° ± 2.0°						Sheet
	X. ± 0.35	.X° ± 1.0°	1/1					
	.X ± 0.25	.XX° ± 0.5°						
	.XX ± 0.15		Unit: mm	Check	Date	Parts No. (Intended Use) JXH0029A1		
			Size: A4	Approved	Date			