

1. Rated Voltage And Current: 300V 8A(CE)
2. Insulating Strength: AC1500V/MIN
3. Insulation Resistance: 500M or more at DC500V
4. Operating Temperature: -40°C/+105°C
5. Storage Condition: Below 85 per cent humidity, storage period: 1 year
6. country of origin: Cixi, Ningbo, China

Material And Size

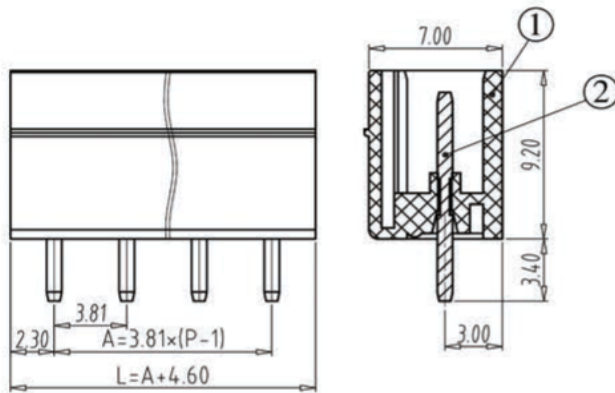

Model: KH-ZBF200V-9P-G

NO.	TITLE	MATERIAL	SPECIFICATION
1	HOUSING	PA66(UL94V-0)	
2	PIN	BRASS	EP-Cu/Cu1-2 Sn3-5um

P.C.B

1. Flow Welding: Solder temperature 260 , welding time up to 6 seconds
2. Manual Weld: 80W Grid iron, about 3 seconds at 400°C for welding

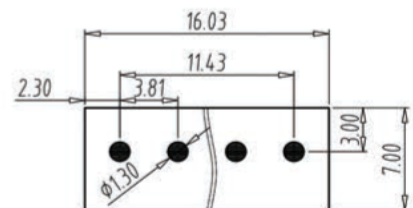

P.C.B. LAYOUT

● FOR PIN

Selection

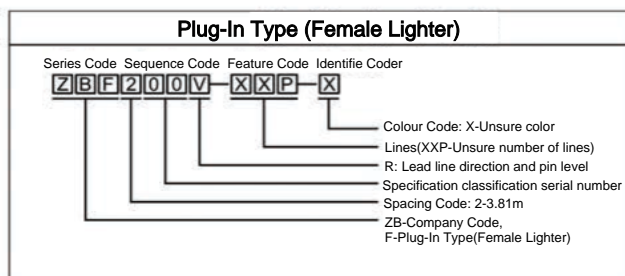

Packaging Bag:

Packaging Size: 20.0x23.0 (cm)

Shenzhen Kinghelm Electronics Co., Ltd	www.kinghelm.net
KH-ZBF200V-9P-G	0755-83044319